



**REQUEST FOR PROPOSALS FOR COGGIN PARK
WALKING TRAIL
Bid # 06-2023**

Date: 6/01/2023

To: Prospective Proposers

From: Roland Soto
Parks and Recreation Director

Bid #: 06-2023

Subject: Coggin Park Walking Trail

SCOPE OF WORK:

Construct a 2,700 LF 8' wide 4" thick concrete walking trail at Coggin Park in Brownwood Texas.

GENERAL SPECIFICATIONS:

- Successful Contractor must comply with all requirements and conditions of this specification. Failure could result in rejection of bid.
- State the standard warranty.
- The successful Contractor shall provide a list of any required scheduled maintenance activities required to ensure compliance with any applicable warranties.
- The successful Contractor shall engage a Licensed Engineer to provide a set of plans based on conceptual drawings (page 7).
- Sidewalk to be placed by Standard Sidewalk Details on page 8.
- TDLR registration required.
- Hiring of ADA Specialist is Proposer's responsibility.

GENERAL SPECIFICATIONS Continued:

- Contractors having questions concerning specifications are requested to contact:

Roland Soto
Parks and Recreation Director
rsoto@brownwoodtexas.gov
512-629-3229

SITE CONDITIONS

- City owned utilities will be marked by the city (water and sewer), all other utilities are the responsibility of

**CITY OF BROWNWOOD TEXAS REQUEST FOR PROPOSALS FOR
COGGIN PARK WALKING TRAIL**

the contractor.

- There may be layers of rock in parts of the installation area. The soil consists of silty sand and clay with some loose stone.
- Proposer's Item Bid Amounts and Total Proposal Amount are to include all costs to complete the Scope of Work in any or all of these Site Conditions.

MINIMUM PROPOSAL REQUIREMENTS

- Description of outside contractors used for any portion of the scope of work.
- Summary of projected timeline for project from contract award to final delivery. Work must be completed by September 1, 2023.
- Employees and Tradesman holding a State issued license in their trade that maintains workers compensation of at least \$500,000.00 and a general liability insurance of at least \$1,000,000.00 which is to be kept on file at Brownwood City Hall.
- Proposals shall include warranty description and provision for all new materials, and labor.

All Proposals shall include the following information:

- Overall construction plan.
- Time to final completion from time of contract award.
- Reputation of company.
- Quality of construction and workmanship.
- Warranty for all new materials.
- Form 1295

Please limit proposals to twenty pages or less.

BIDDING PROCEDURES:

The City of Brownwood will accept Sealed Proposals until June 22, 2023, at 10:00 AM CST for the **Coggin Park Walking Trail – 06-2023**.

Proposals are to be delivered to the office of the Purchasing Manager, Jenny Yazell at the City of Brownwood City Hall, 501 Center Avenue, Brownwood, TX 76801 or mailed to P O Box 1389, Brownwood, TX 76804, clearly marked as "**Coggin Park Walking Trail – 06-2023**".

Proposal Bid Amounts must be submitted on the City's Proposal Bid Form provided in the Request for Proposals. The Bid Proposal Form must be signed and dated by the Proposers authorized representative or Officer. Additional requested Proposal information should be attached as Exhibits to the Bid Proposal Form

Proposer's Item Bid Amounts and Total Proposal Amount are to include all costs to complete the Work, including but not limited to General Conditions and Requirements, overhead and profit, bonds and insurance, mobilization, transportation, supervision, labor, suppliers, and subcontractors.

A bid bond in the amount of 10 percent of the bid issued by an acceptable surety shall be submitted with each proposal. A certified check or bank draft payable to the City of Brownwood or negotiable U.S Government Bonds (as par value) may be submitted in lieu of the Bid Bond.

Attention is called to the fact that not less than the prevailing wage rate must be paid on this project. In addition, the successful proposer must ensure that employees and applicants for employment are not discriminated against because of race, color, religion, sex, sexual identity, gender identity, or national origin.

**CITY OF BROWNWOOD TEXAS REQUEST FOR PROPOSALS FOR
COGIN PARK WALKING TRAIL**

Attention is called to the fact that the State of Texas Government Code mandates that a city contracting for public work in excess of \$50,000 shall require its contractor to execute a payment bond. The Government Code also mandates that a city contracting for public work in excess of \$100,000 shall require its contractor to execute a performance bond. The successful Proposer (Contractor) must provide a payment bond and a performance bond when required per Texas State Law.

Attention is called to the fact that a Public Works project that exceeds \$20,000 must engage a Licensed Engineer for the project.

Contractors must be insured and bonded and CARRY CURRENT workers compensation insurance for all employees working at the site.

Proposal Field Verification: During design and construction the respondent may encounter existing conditions that were unknown during this request for responses. The Proposer shall field verify all existing conditions prior to proceeding with the work and address all discoveries that interfere with proper execution of the work and/or jeopardize the structural integrity of the structure.

The successful Proposer's will be required to submit a 1295 Form per Texas State Law as set forth below:

Texas Government Code 2252.908 Disclosure of Interested Parties Form 1295 House Bill 1295, adopted by the 84th Legislature, created §2252.908, Texas Government Code. Section 2252.908 requires a business entity entering into certain contracts with a governmental entity or state agency to file with the governmental entity or state agency a disclosure of interested parties at the time the business entity submits the signed contract to the governmental entity or state agency. §2252.908, Texas Government Code requires the commission to adopt rules necessary to implement the new disclosure requirement and to prescribe the disclosure form. Section 2252.908 requires the disclosure form to be signed by the authorized agent of the contracting business entity, acknowledging that the disclosure is made under oath and under penalty of perjury. Section 2252.908 applies only to a contract that requires an action or vote by the governing body of the governmental entity or state agency before the contract may be signed or has a value of at least \$1 million. Section 2252.908 provides definitions of certain terms occurring in the section. House Bill 1295 provides that §2252.908 applies only to a contract entered into on or after January 1, 2016. An interested party is defined as a person who has a controlling interest in a business entity with whom a governmental entity or state agency contracts or who actively participates in facilitating the contract or negotiating the terms of the contract, including a broker, intermediary, adviser, or attorney for the business entity. Contractors are required to acquire Form 1295 via the Texas Ethics Commission website. This requires registration, generation of Form 1295 with a unique Certificate Number & filing date, printing the form, notarizing and returning the form to City of Brownwood Purchasing Department, Attn: Jenny Yazell, City of Brownwood, at jyazell@brownwoodtexas.gov. Once the form is received by Ms. Yazell, the Vendor associated with the project will log-in to the Texas Ethics Commission portal and acknowledge receipt of the form not later than the 30th day after the date the contract for which the form was filed binds all parties to the contract. This will complete the form for the contract with which the form is associated. The completed form will be made available via the Texas Ethics Commission website. Form 1295 can be generated via the Texas Ethics Commission web portal. The website and detailed instructions are located at: https://www.ethics.state.tx.us/whatsnew/elf_info_form1295.htm

A Proposer shall also submit a Conflict-of-Interest Questionnaire with their Proposal as follows:

Effective January 1, 2006, Chapter 176 of the Texas Local Government Code requires that persons, entities, or their agents, which seek to contract for the sale or purchase of property, goods, or services with City, shall file a completed Conflict of Interest Questionnaire (hereafter referred to as "CIQ") with City Clerk not later than the seventh (7th) business day after the date that the person, entity, or agent:

(a) begins contract discussions or negotiations with City; or

**CITY OF BROWNWOOD TEXAS REQUEST FOR PROPOSALS FOR
COGIN PARK WALKING TRAIL**

(b) submits to City an application, a response to a request for bid, a proposal, correspondence related to a bid/proposal or another writing related to a potential agreement with City.

The CIQ form is available from the Texas Ethics Commission online at the following web address: <http://www.ethics.state.tx.us/forms/CIQ.pdf>.

Completed CIQ forms shall be submitted with the Proposal. Respondent shall consult its own legal advisor if Respondent has questions regarding the Local Government Code statute or the CIQ form.

All materials and work are FOB Brownwood, Texas.

The City of Brownwood is a Tax-Exempt entity.

Any reference in this Request for Proposal to a particular equipment or material manufacturer, supplier, product, or process in the Contract or Bid Documents is descriptive, not restrictive. The City, at its sole discretion, reserves the right to consider suitable alternate equipment or material manufacturers, suppliers, or processes that provide equal or better value.

The following provisions shall be in a contract with the Proposer should their Proposal be awarded by the City.

REQUIRED CONTRACT PROVISIONS:

No Israel Boycott. In accordance with Chapter 2271, Texas Government Code, a Texas governmental entity may not enter into an agreement with a company for the provision of goods or services unless the agreement contains a written verification from the company that it: (1) does not boycott Israel; and (2) will not boycott Israel during the term of the agreement. Chapter 2271 does not apply to (1) a company that is a sole proprietorship; (2) a company that has fewer than ten (10) full-time employees; or (3) an agreement that has a value of less than One Hundred Thousand Dollars (\$100,000). Unless the company is not subject to Chapter 2271 for the reasons stated herein, the signatory executing this agreement on behalf of _____ verifies by their signature on this Agreement that the company does not boycott Israel and will not boycott Israel during the term of this Agreement.

No Energy Company Boycott. In accordance with Chapter 2274, Texas Government Code, a Texas governmental entity may not enter into an agreement with a company for the provision of goods or services unless the agreement contains a written verification from the company that it: (1) does not boycott energy companies; and (2) will not boycott energy companies during the term of the agreement. Chapter 2274 does not apply to (1) a company that is a sole proprietorship; (2) a company that has fewer than ten (10) full-time employees; (3) an agreement that has a value of less than One Hundred Thousand Dollars (\$100,000) or (4) an agreement entered into or in connection with or relating to the issuance, sale, or delivery of notes under Subchapter H, Chapter 404, or the administration of matters related to the notes, including the investment of note proceeds, is exempt as is determined by the Texas Comptroller. Unless the company is not subject to Chapter 2274 for the reasons stated herein, the signatory executing this agreement on behalf of _____ verifies by their signature on this Agreement that the company does not boycott energy companies and will not boycott energy companies during the term of this Agreement.

No Discrimination Against Firearm Entity or Firearm Trade Association. In accordance with Chapter 2274, Texas Government Code, a Texas governmental entity may not enter into an agreement with a company for the provision of goods or services unless the agreement contains a written verification from

**CITY OF BROWNWOOD TEXAS REQUEST FOR PROPOSALS FOR
COGIN PARK WALKING TRAIL**

the company that it: (1) does not have a written or unwritten internal practice, policy, guidance, or directive that discriminates against a firearm entity or firearm trade association based solely on its status as a firearm entity or firearm trade association; and (2) will not discriminate against a firearm entity or firearm trade association based solely on its status as a firearm entity or firearm trade association during the term of this Agreement. Chapter 2274 does not apply to (1) a company that has fewer than ten (10) full-time employees; or (2) an agreement that has a value of less than One Hundred Thousand Dollars (\$100,000). Unless the company is not subject to Chapter 2274 for the reasons stated herein, the signatory executing this agreement on behalf of _____ verifies by their signature on this Agreement that the company does not have a written or unwritten internal practice, policy, guidance, or directive that discriminates against a firearm entity or firearm trade association based solely on its status as a firearm entity or firearm trade association; and will not discriminate against a firearm entity or firearm trade association based solely on its status as a firearm entity or firearm trade association during the term of this Agreement.

OPENING OF PROPOSALS:

Proposals will then be opened by the Purchasing Manager on June 22, 2023, at 10:00 AM in the City Council Chambers, Brownwood City Hall, 501 Center Avenue, Brownwood, Texas.

AWARD OF CONTRACT:

The City Council may award the proposal at its Tuesday, June 27, 2023, Council meeting.

The City Council retains the right to reject any and all proposals submitted and to waive any irregularities in the bids. The City Council reserves the right to cancel the project without any obligation to the proposers. The City Council may award the proposal to the proposer that presents the best value for the City pursuant to Gov't Code Section 2269.055 using the criteria set forth herein. In determining best value for the City, the City Council shall consider: (1) the price; (2) the reputation and experience of the contractor; (3) the quality of the contractor's services; (4) the impact on the ability of the City to comply with rules relating to historically underutilized businesses; (5) the contractor's safety record; (6) the contractor's proposed personnel and (7) whether the contractor's financial capability is appropriate to the size and scope of the project; and (8) the contractor's past relationship with the City (the "Proposal Evaluation Criteria"). In determining best value, the City will give the criteria the following weighted values: price – 50%; the remaining criteria shall be valued equally. Following receipt of Proposals, each Proposal will be ranked according to the Proposal Evaluation Criteria within 7 days of the opening date. The City will select the proposer that demonstrates the best value for the City based on the Proposal Evaluation Criteria. The City will first attempt to negotiate a contract with the selected proposer. Negotiations may include options for scope or time modification and any related price change. If the City is unable to negotiate a contract with the selected proposer, the City will, formally and in writing, end negotiations with that proposer and proceed to the next ranked proposer until a contract is reached or all proposals are rejected. The City may select representatives to assist in ranking and negotiations. Award of Contract, if any, will be made by formal action of the City of Brownwood City Council.

**CITY OF BROWNWOOD TEXAS REQUEST FOR PROPOSALS FOR
COGIN PARK WALKING TRAIL**

PROPOSAL BID FORM

ITEM NO.	DESCRIPTION	UNIT	QUANTITY	AMOUNT	TOTAL AMOUNT*
1	8'x4" Concrete sidewalk	LF	2700	\$ _____	\$ _____
2	Excavation	CY.	200	\$ _____	\$ _____
3	Backfill	CY.	75	\$ _____	\$ _____
PROPOSAL TOTAL BID AMOUNT:					\$ _____
PROPOSAL TOTAL BID AMOUNT: (In Words)					

_____ Dollars					
(and) _____ Cents					
PROPOSERS AUTHORIZED SIGNATURE:					
TITLE:					
DATE:					

*Total Amount = QUANTITY x AMOUNT

**CITY OF BROWNWOOD TEXAS REQUEST FOR PROPOSALS FOR
COGIN PARK WALKING TRAIL**

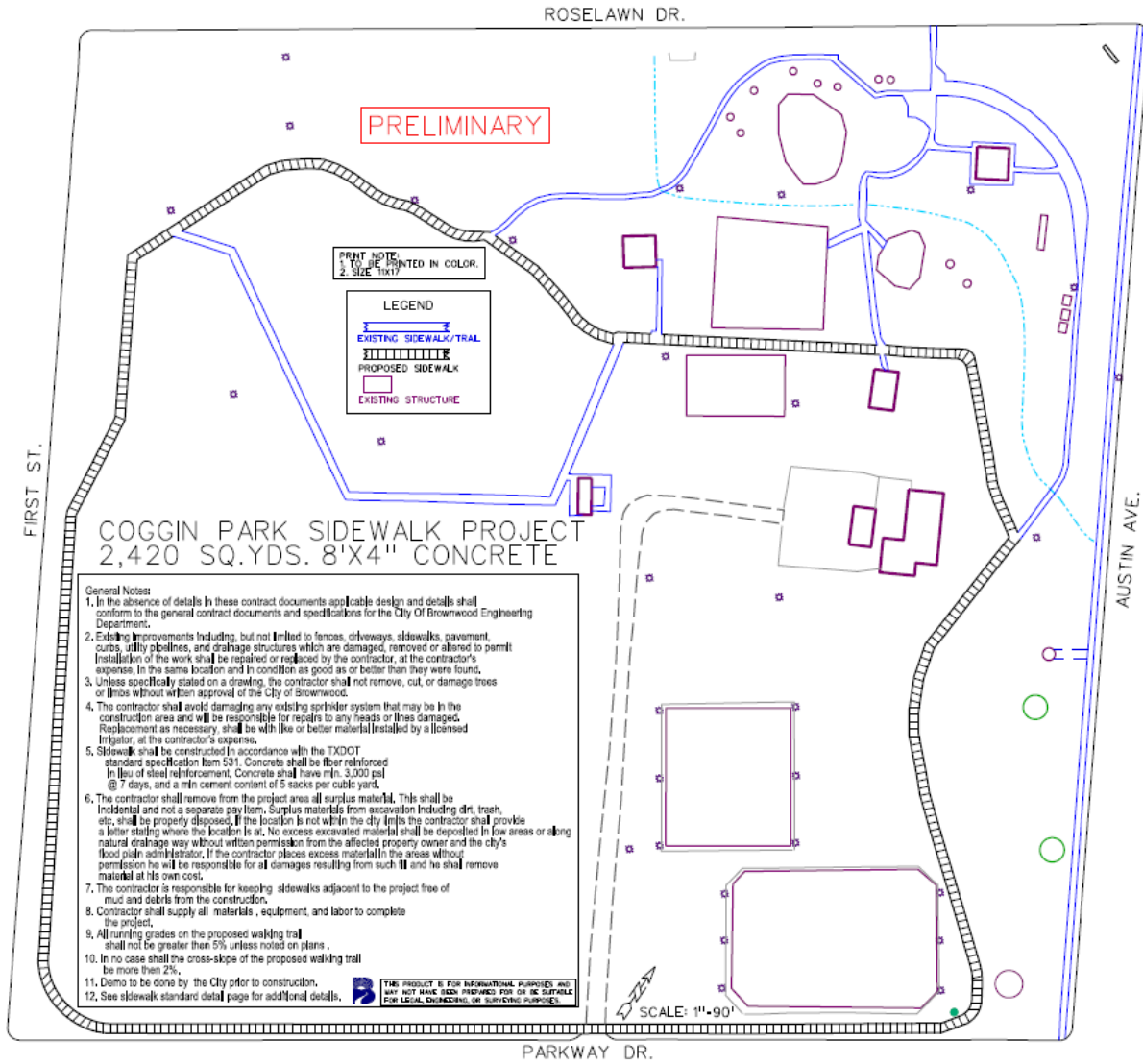

**CITY OF BROWNWOOD TEXAS REQUEST FOR PROPOSALS FOR
COGIN PARK WALKING TRAIL**

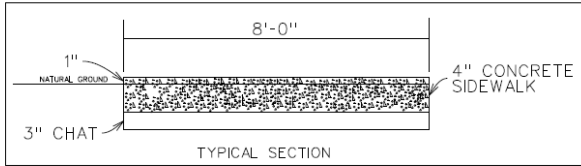
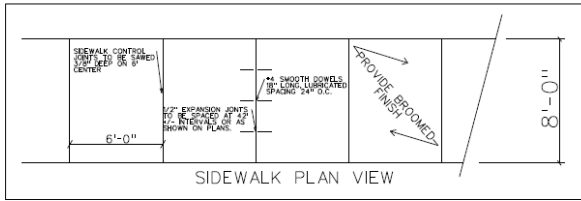

- General Notes:**
- In the absence of details in these contract documents applicable design and details shall conform to the general contract documents and specifications for the City Of Brownwood
 - Existing Improvements Including, but not limited to fences, driveways, sidewalks, pavement, curbs, utility pipelines, and drainage structures which are damaged, removed or altered to permit installation of the work shall be repaired or replaced by the contractor, at the contractor's expense, in the same location and in condition as good as or better than they were found.
 - Unless specifically stated on a drawing, the contractor shall not remove, cut, or damage trees or limbs without written approval of the City of Brownwood.
 - The contractor shall avoid damaging any existing sprinkler system that may be in the construction area and will be responsible for repairs to any heads or lines damaged. Replacement as necessary, shall be with like or better material installed by a licensed Irrigator, at the contractor's expense.
 - Sidewalk shall be constructed in accordance with the TXDOT standard specification Item 531. Concrete shall be fiber reinforced in lieu of steel reinforcement. Concrete shall have min. 3,000 psi @ 7 days, and a min cement content of 5 sacks per cubic yard.
 - The contractor shall remove from the project area all surplus material. This shall be incidental and not a separate pay item. Surplus materials from excavation including dirt, trash, etc. shall be properly disposed. If the location is not within the city limits the contractor shall provide a letter stating where the location is at. No excess excavated material shall be deposited in low areas or along natural drainage way without written permission from the affected property owner and the city's flood plain administrator. If the contractor places excess material in the areas without permission he will be responsible for all damages resulting from such fill and he shall remove material at his own cost.
 - The contractor is responsible for keeping sidewalks adjacent to the project free of mud and debris from the construction.
 - Contractor shall supply all materials, equipment, and labor to complete the project.
 - All running grades on the proposed walking trail shall not be greater than 5% unless noted on plans.
 - In no case shall the cross-slope of the proposed walking trail be more than 2%.
 - Demo to be done by City prior to construction.

**SIDEWALK STANDARD
DETAILS** PRELIMINARY

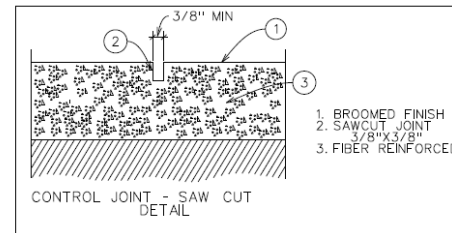
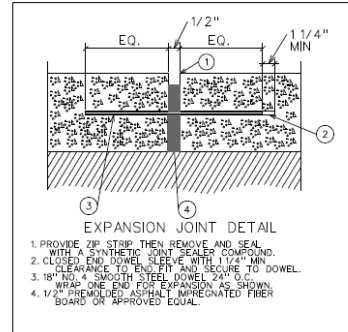

THIS PRODUCT IS FOR INFORMATIONAL PURPOSES AND MAY NOT HAVE BEEN DESIGNED FOR OR BE SUITABLE FOR LEGAL, ENGINEERING, OR SURVEYING PURPOSES.

CITY OF BROWNWOOD TEXAS REQUEST FOR PROPOSALS FOR
COGIN PARK WALKING TRAIL

Addendum: #01

Addendum Issue Date: June 2, 2023

The following changes to the Request for Proposal must be considered when completing your submittal: Acknowledgement of receipt of this ADDENDUM is required.

1. **Page 1, bullet point four** shall read: "The successful Contractor shall engage a Licensed Engineer to provide a set of plans based on conceptual drawings (page 7)."
2. **Page 1, bullet point six** shall read: "TDLR registration required."
3. **Page 1, bullet point seven** shall read: "Hiring of ADA Specialist is Proposer's responsibility."
4. **Page 3, paragraph two** shall read: "Attention is called to the fact that a Public Works project that exceeds \$20,000 must engage a Licensed Engineer for the project."

All other terms, conditions, and requirements set forth in RFP No. 06-2023 remain unchanged and in effect.

Please sign and return this addendum with the **PROPOSAL BID FORM**.

Printed Name of Proposer/Contractor (Person, Firm, or Corporation)

Signature of Proposer/Contractor